



ECUATEPI S.A.

DATASHEET

**FIRE
ENGINEERING**

EXTINGUISHERS

Industrial Monitors

Unique Features of Protek Industrial Monitors

- 1 Flow turning vanes in each elbow to reduce friction
- 2 Powder coating gives a tough corrosion resistant finish
- 3 Positive friction locks with bronze knob on both horizontal and vertical
- 4 Stainless steel lever
- 5 Major components made from bronze alloy (UNS C83600, ASTM B62) for a long in serving life
- 6 Able to be supplied with flange options:
ANSI, ASA, DIN or ISO. Special alloy flanges are available
- 7 A double row of stainless steel ball bearing in monitor joints ensure easy movement even when monitor is under pressure
- 8 A comprehensive range of water and self educting foam master stream nozzle available to fit for any application



Manuel Larrea N17-241 y Santiago
Telefax: 02 222-9444 / Cell: 0987178263
Email: info@ecuatepi.com



ECUATEPI S.A.

DATASHEET

**FIRE
ENGINEERING**

EXTINGUISHERS

Style #649 Monitor

- Corrosion resistant bronze construction Ideal for marine, offshore, industrial or other corrosive environment
- Full 3" waterway
- Cast-in turning vanes for efficient flow
- Flow Up to 1,250 GPM (4,800 LPM)
- 360 degrees horizontal and 150 degrees vertical travel 90 degree above to 60 degree below horizontal
- Positive friction locks on both horizontal and vertical travel to hold the desired position
- Stainless steel lever
- Operating pressure of 200 PSI (14 bar)

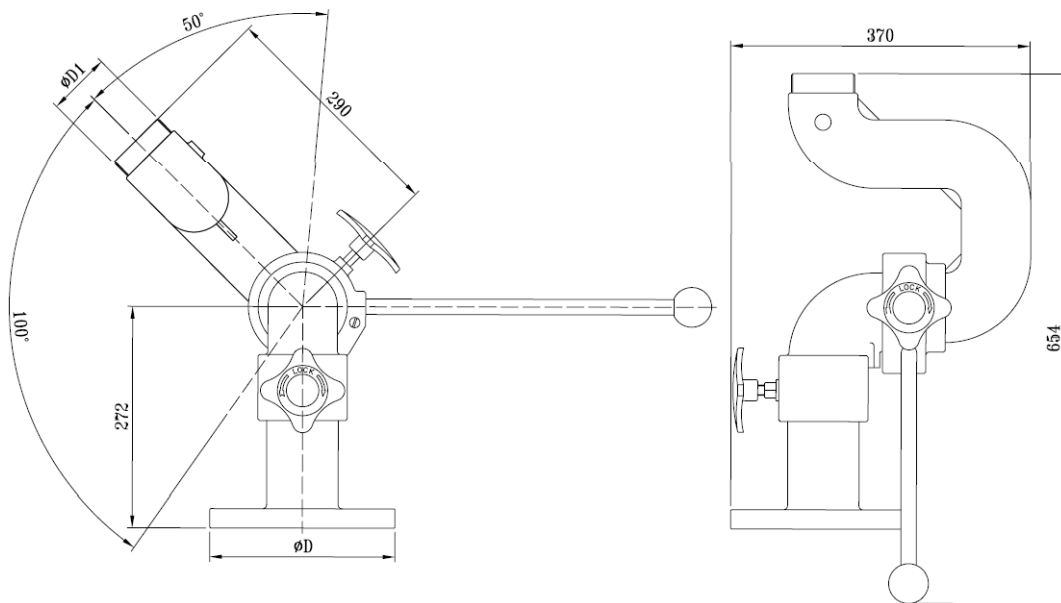

STYLE	HEIGHT	WIDTH	INLET	OUTLET	WEIGHT LBS	FLOW
						GPM
649	17"	14"	3" or 4" FL	2.5"	46	1,250

Manuel Larrea N17-241 y Santiago
Telefax: 02 222-9444 / Cell: 0987178263
Email: info@ecuatepi.com